

GRAFA 250 Series

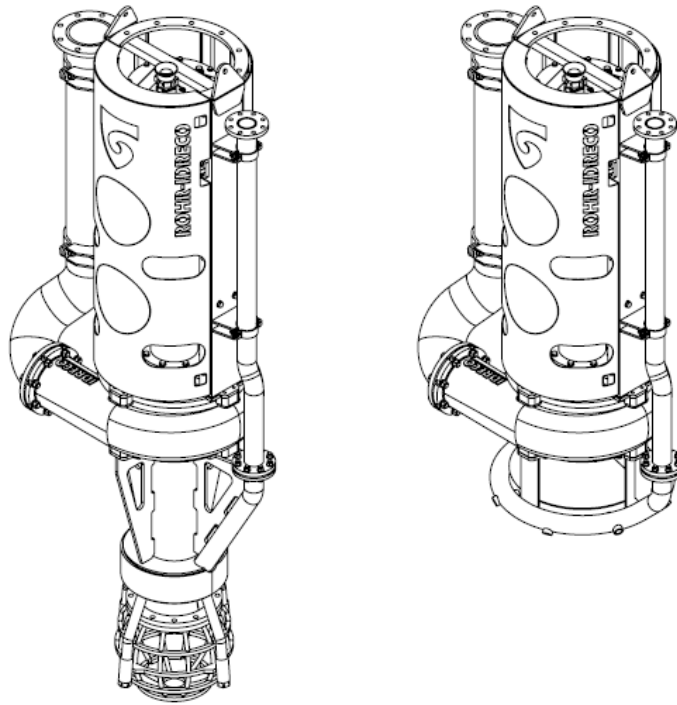

FEATURES

Efficient Electric Drive System
 Small Environmental Footprint
 Low Noise & Vibration Level
 Remote Operation
 Easy transport

DREDGING FEATURES

Max. Dredging Depth	50 [m]
Nominal Mixture Flow	500 - 1000 [m ³ /h]
Suction Diameter	250 [mm]
Discharge Diameter	200 [mm]
Max. Spherical Pump Passage	119 [mm]

DREDGE PUMP DRIVE

Power Source	Electric feed cable
Direct drive	Gear coupling
Available Dredge Pump Power	260 [kW]

JET PUMP

Jet Pump Flow	120 / 150 / 180 [m ³ /h]
Jet Pump Pressure	8 [bar]
No. Jet Nozzles	4 / 8 [pcs]

PRINCIPLE DIMENSIONS

Total length with suction head	3.6 [m]
Total length with leveller head	2.5 [m]
Width	1.4 [m]
Total dry weight	2.5 [ton]

ELECTRIC INSTALLATION

Primary Voltage	690 [V]
Dredge Pump Power Source	VFD
Jet Pump Power Source	Soft starter / VFD

TOOLS

Special tools are supplied for maintenance of dredge pump

INSTRUMENTATION

- Simple Dredger Control System
- Dredging Depth Indication
- Vacuum and Pressure Indication of Dredge Pump

OPTIONAL EQUIPMENT

- Leveller head / suction head
- Production Measurement
- Discharge Velocity Measurement
- Additional Hydraulic Excavation Head
- Floating discharge pipe line
- Remote dredge monitoring
- Floating high voltage supply cable